

**Dear Customer,**

Thank you for the confidence you have bestowed on our company by choosing to purchase one of our devices. Prior to its use, for the sake of your own safety, please review carefully information about the product provided below.

**PRIMUS LED EMERGENCY POWER SUPPLY KIT**

Primus LED is intended for installation in lighting fittings equipped with LED light source powered directly from 230V mains (versions A9 and D9) or through an external constant current or constant voltage LED driver (versions D1, D2, D3, D4, D6, D8, D8.5, D10.180, D10.210 and D10.240). The emergency module features compact dimensions for mounting in small lighting fittings. The kit features a DC powered electronic ballast and a battery pack with mounting brackets. When installed, the kit enables to adapt any lighting fitting to operate in emergency as well as mains - emergency mode.

**OPERATION PRINCIPLE**

The emergency module detects a failure of 230V/50Hz power and using the power stored in the battery it begins to generate high relevant voltage, necessary for power supply of LED lamps. The duration of emergency operation depends on LED light source power rating and the capacity of battery used. The converter reaches its full efficiency after 24 hours from connection to or restore of normal voltage. In the event of a failure of 230V/50Hz power before those 24h, the duration of emergency operation of the device will depend on the level of battery charge. Under normal conditions, i.e. when supplied with 230V/50Hz power, the converter charges the attached pack of high temperature batteries in a continuous mode. Battery charging as well as presence of 230V/50Hz AC power is signalled by the green LED of the module.

**CONNECTION DIAGRAM**

The connection diagram presented below is of illustrative nature. If in doubt, please contact a qualified electrician or the distributor from whom you purchased the unit, or directly with our technical department.

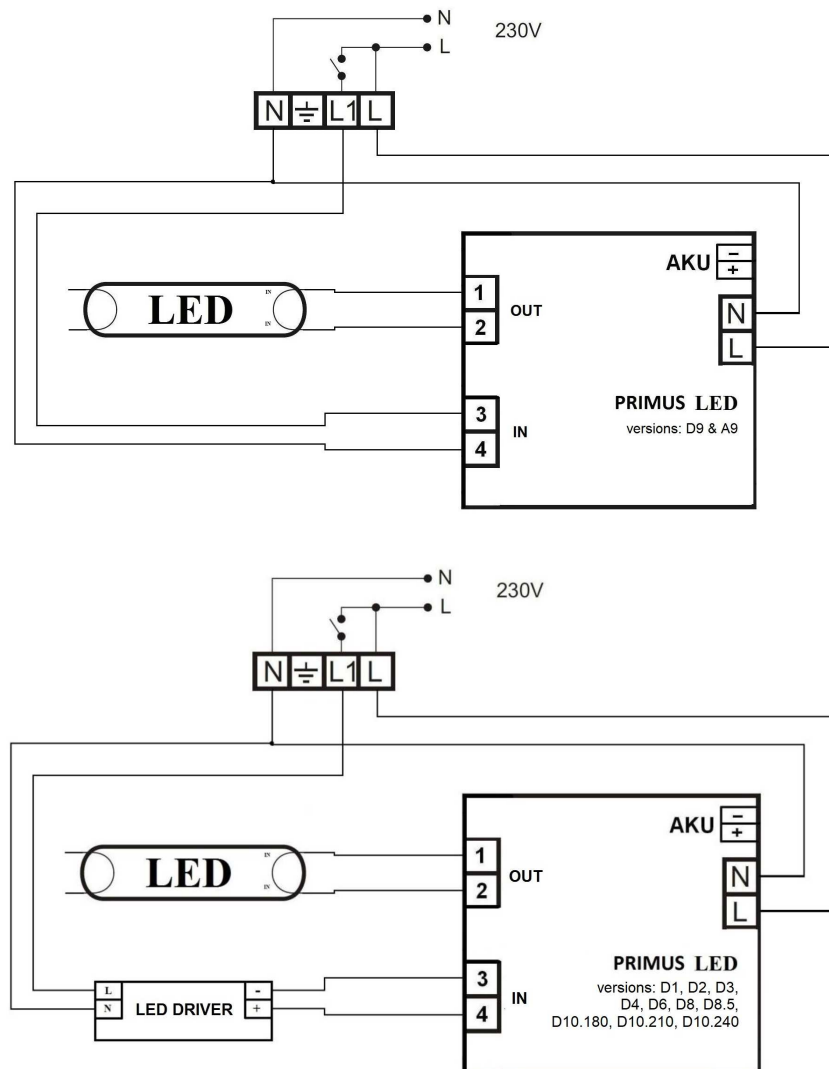

**CAUTION! Never operate the emergency module without load!**

**Before starting up the device, check that the LED light source has been properly connected to the system!**

**GUIDANCE FOR USER**

- Factory packed converter is disconnected from the battery. In this state it must not be stored in subzero temperatures as it may cause a rapid discharge. During storage make sure the battery is not excessively discharged. The voltage of a battery pack cell should not drop below its nominal value (e.g 3.6V for a 3-cell pack). Recharge by connecting the battery to the converter and connecting the lighting fitting to 230V/50Hz for at least 24 hours.
- It is recommended to run battery pack charging cycle during the first start up of the emergency power supply, the cycle should be at least 24 hours long. Furthermore, it is worthwhile to format the batteries in order to increase their life. Formatting is achieved by performing three cycles of full charge and discharge of the batteries. Discharge the battery pack by disconnecting the mains power. The lighting fitting will then switch to emergency mode.
- To avoid unnecessary discharge of the battery pack, connect it to the emergency module only after installing the LED lamp and connecting it to the mains power. Test of the emergency lighting operation is done by disconnecting the mains power and measuring the duration of emergency operation. If it is too short, replace the batteries after checking the electrical system for proper operation.
- Regardless of the degree of wear of the batteries, it is recommended to replace them every four years.
- The lighting fitting should work in the emergency mode only with fully charged battery. Never disable periodically the charging voltage.
- Intelight Sp. z o.o. reserves the right to change the design of the product.

## GUARANTEE

Intelight Sp. z o.o. provides free removal of faults resulting from defects in material and workmanship by repairing or replacement of the device, for a period of two years from the date of purchase. In case of malfunction, please deliver the product to the place of purchase along with a warranty tag. The guarantee shall not cover wearing parts as well as defects resulting from improper operation of the device, in particular mechanical damage or malfunction caused by temperature or chemical agents. Please also note that the costs of unjustified complaint shall be charged to the customer. For complete guarantee details please visit our website at: [www.intelight.eu](http://www.intelight.eu).

## DECLARATION OF CONFORMITY

The products described herewith meet the requirements of the following EU Directives:

- Low Voltage Directive LVD (2014/35/EU);
- Electromagnetic Compatibility Directive EMC (2014/30/EU).

## TECHNICAL SPECIFICATIONS:

- Power supply voltage: AC 230V/50Hz
- Operating frequency: 20kHz – 40kHz
- Mains power consumption: max. 4W
- Module's output power: 2W approx.
- Time needed to switch to emergency mode: 0.2 - 0.8s
- Ambient temperature (Ta): +5 ÷ +50°C
- Operating temperature (Tc): +70°C
- Battery used: maintenance free, high temperature NiCd HT batteries as a standard and NiMH HT batteries as an option.
- Battery pack voltage: 3.6V or 4.8V
- Battery capacity: 1h – 1.5Ah, 2h – 2.5Ah, 3h – 4Ah
- Maximum battery charging duration: 24h
- Mounting: in the lighting fitting, with crews
- Lighting fitting colour: white
- Dimensions (H/W/L): 32/42/152

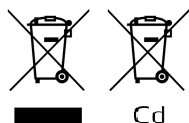

Pursuant to the Act of 29 July 2005 on waste electrical and electronic equipment and the Act of 24 April 2009 on batteries and accumulators, the presented device, after use, due to hazardous substances contained in it, is subject to collection of waste electrical and electronic equipment. Detailed information on WEEE collection can be obtained from municipal authorities.